



ITT

IM158

Commercial Water

Goulds Pumps

Model SMVT

Installation, Operation and Maintenance Instructions



Goulds Pumps is a brand of ITT Corporation.

www.goulds.com

Engineered for life

Table of Contents

Introduction and Safety	2
Transportation and Storage.....	7
Product Description.....	8
Installation.....	11
Commissioning, Startup, Operation and Shutdown	20
Maintenance	23
Troubleshooting.....	33
Appendix.....	34
Warranty.....	38

Owners Information

Complete this information for your records.
Model number and serial number may be found
on the tag mounted to the motor adapter.

Model Number _____

Serial Number _____

Dealer _____

Dealer phone number _____

Date of purchase _____

Date of installation _____

I. Introduction and Safety

Introduction

Description

This manual provides instructions for the Installation, Operation and Maintenance of the Goulds Model SMVT pumps. This manual covers the standard product plus common options that are available.

Requirement

This manual must be read and understood before installation and start-up. Goulds shall not be liable for physical injury, damage or delays caused by a failure to observe the instructions for installation, operation and maintenance contained in this manual.

Content

This instruction manual covers several different pump models that all have similar power end configurations. Most assembly, disassembly and inspection procedures are the same for all the pumps. However, where there are differences, they are called out separately within the manual. The design, materials and workmanship incorporated in the construction of Goulds pumps makes them capable of giving long, trouble free service. The life and satisfactory service of any mechanical unit, however, is enhanced and extended by correct application, proper installation, periodic inspection, condition monitoring and careful maintenance. This instruction manual was prepared to assist operators in understanding the construction and the correct methods of installing, operating and maintaining these pumps.

Key Topics

- Transportation and Storage
- Product Description
- Proper Installation
- Start up Procedures
- Operation Procedures
- Routine Maintenance
- Pump Overhaul
- Trouble Shooting
- Identifying Spare or Repair Parts

Safety

It is extremely important that you read, understand, and follow the safety messages and regulations carefully before handling an ITT product. They are published to help prevent

- personal accidents and health problems
- damage to the product
- product malfunction

Observe all safety messages highlighted in other sections of this manual.





A pump is a pressure-containing device with rotating parts that can be dangerous.



Caution: You must observe the instructions for installation, operation, and maintenance contained in this manual. Failure to do so could result in physical injury, damage, or delays.

Safety message levels

Table 1: Definitions

Safety message level	Indication
 <u>Danger:</u>	Indicates a hazardous situation which, if not avoided, will result in death or serious injury.
 <u>Warning:</u>	Indicates a hazardous situation which, if not avoided, could result in death or serious injury.
 <u>Caution:</u>	Indicates a hazardous situation which, if not avoided, could result in minor or moderate injury.
<u>Note:</u>	Indicates a potential situation which, if not avoided, may result in undesirable results or state. Indicates a practice not related to personal injury.
 <u>Electrical Hazard:</u>	Indicates the possibility of electrical risks if directions are not applied in a proper manner.

Environmental safety

Preventive measures for the working area

Always keep the pump station clean to avoid and/or discover emissions.

Recycling guidelines

Always recycle according to the guidelines listed below:

1. Follow local laws and regulations regarding recycling if the unit or parts are accepted by an authorized recycling company.
2. If the first guideline is not applicable then return the unit or parts to the nearest ITT representative.

Waste and emissions

Observe these safety regulations regarding waste and emissions:

- Properly dispose of all waste.
- Handle and dispose of the pumpage in compliance with applicable environmental regulations.
- Clean-up all spills in accordance with safety and environmental procedures.
- Report all environmental emissions to the appropriate authorities.

Reference for electrical installation

For electrical installation recycling requirements, consult your local electric utility.

User health and safety

Safety equipment

Use safety equipment according to the company regulations. The following safety equipment should be used within the working area depending on the fluid being pumped:

- helmet
- safety goggles (with side shields)
- protective shoes
- protective gloves
- gas mask
- hearing protection

Note: The noise level of the product is lower than 70 dB. However, the noise level of 70 dB may be exceeded in some installations and at certain operating points on the performance curve. Make sure that you understand the noise level requirements in the environment where the pump is installed. Failure to do so may result in hearing loss or violation of local laws.

The working area

Observe these regulations and warnings in the working area:

- Always keep the work area clean.
- Pay attention to the chemical and physical characteristics of the gas and vapors present in hazardous areas.
- Avoid all electrical dangers. Pay attention to the risks of electric shock or arc flash hazards.

Product and product positioning requirements

Observe these requirements for the product and the product positioning:

- Never operate a pump unless safety devices are installed.
- Three-phase motors must have a properly sized starter with properly sized heaters to provide overload and undervoltage protection. Single-phase motors have built-in overload protectors.
- Never start a pump without the proper priming.
- Never run a pump below the minimum rated flow or with any suction or discharge valve closed.

Electrical connections

Electrical connections must be made by authorized electricians in compliance with all international, national, state and local rules.

Observe the following regulations and warnings for electrical connections.

- Make sure that the product is isolated from the power supply and can not be energized by mistake. This rule applies to the control circuit as well.
- Make sure that the thermal contacts are connected to a protection circuit according to the product approvals, and that they are in use.

Observe the following regulations for grounding connections.

Table 2: Grounding

Grounding regulation	Comment
All electric equipment must be grounded.	This rule applies to pumps as well as monitoring equipment.

Precautions before work

Observe the following safety precautions before working with or in connection with the product:

- Make sure that there are no poisonous gases within the work area.
- Provide a suitable barrier around the work area, for example a guard rail.
- Make sure that all safety guards are in place and secure.
- Make sure that the equipment is properly insulated when operating at extreme temperatures.
- Allow all system and pump components to cool before you handle them.
- Make sure that you have a clear path of retreat.
- Make sure that the product cannot roll or fall over and injure people or damage property.
- Make sure that the lifting equipment is in good condition.
- Use a lifting harness, a safety line, and a breathing device as required.
- Make sure that the product has been thoroughly cleaned.
- Make sure that a first-aid kit is close at hand.
- Check the explosion risk before welding or using electric hand tools.

Precautions during work

Observe the following safety precautions when working with or in connection with the product:

- Never work alone.
- Stay clear of suspended loads.
- Always lift the product by its lifting device.
- Beware of the risk of a sudden start if the product is used with an automatic level control.
- Beware of the starting jerk, which can be powerful.
- Rinse the components in water after disassembling the pump.
- Do not exceed the maximum working pressure of the pump.
- Do not open any vent or drain valves or remove any plugs while the system is pressurized. Ensure that the pump is isolated from the system and that pressure is relieved before you disassemble the pump, remove plugs, or disconnect piping.

- Always bear in mind the risk of:
 - electrical accidents
 - burn injuries

Clean chemicals from the eyes

1. Forcibly hold the eyelids apart with the fingers.
2. Rinse the eyes for at least 15 minutes. Use an eyewash or running water.
3. Seek medical attention.

Clean chemicals from the body

1. Remove contaminated clothing.
2. Wash the skin with soap and water for at least 1 minute.
3. If required, seek medical attention.

Product approval standards

Regular standards

All electrical ratings and performance of the motors comply with UL, CSA and NEMA standards.

Product warranty

Personnel requirements

All work on the product must be carried out by certified electricians and ITT authorized mechanics.

ITT disclaims all responsibility for work done by untrained and unauthorized personnel.

Modification and spare parts

Modifications or changes to the product/installation should only be carried out after consulting with ITT. Original spare parts and accessories authorized by ITT are essential for compliance. The use of other parts can invalidate any claims for warranty or compensation and explosion-proof approvals.

Warranty claim

For warranty claim, contact your ITT Fluid Technology representative.

II. Transportation and Storage

Description

This section describes recommended methods for receiving, storing and handling the pump prior to physical installation.

Receiving

The pump should be uncrated or unboxed when it is received so that it can be completely inspected. Carefully check that everything is in good order. Make notes of damaged or missing items on the receipt and freight bill. File any claims with the transportation company as soon as possible.

Storage

Short Term: For storage of less than six months, the normal packaging procedures used by Goulds Pumps are designed to protect the pump during shipping. After receipt, store in a covered and dry location.

Long Term: For storage of more than six months, preservative treatment of bearings and machined surfaces will be required. Rotate the pump and motor shaft several times every three months. Refer to driver manufacturers for their long term storage procedures. Store in a covered, dry location.

Handling



Warning: Pump and components are heavy. Failure to properly lift and support equipment could result in serious physical injury or damage to pumps. Steel toed shoes must be worn at all times.

Use care when moving pumps. Lifting equipment must be able to adequately support the pump assembly. Hoist pump using a suitable sling under the motor adapter as shown in Figure 1. DO NOT lift the pump with the motor installed to the pump assembly.



Consult the motor manufacturer's Installation, Operation, and Maintenance manual supplied with your motor for proper handling procedures for the motor assembly.

Figure 1: Proper Lifting

III. Product Description

Description

This section provides a general description of the Goulds Model SMVT and key engineering specifications.

Overview

The Goulds model SMVT pumps are surface mounted, multi-stage, vertical turbine pumps. Pump impellers are closed, shaft driven, and held in position by a positive-locking taper collet.

Suction and discharge connections are ANSI standard 3 inch 125# or 250# and 4 inch 125# or 250# flange type.

Pumps are available with standard ODP or TEFC motors.

Intended Use

Commercial Applications:

Booster Units
High Rise Building Water Applications
HVAC

Municipal Applications:

Package Pump Stations
Booster Stations
Water Treatment Applications

Irrigation Applications:

Turf Irrigation
Golf Courses
Stadiums
Greenhouses/ Nurseries
Sprinkler Systems

Engineering Data

Torque Values

Table 3: Torque Values

Description	Torque (ft.-lbs.)
Motor Bolts – 3, 5, 7.5 HP motors	20
Motor Bolts – 10 to 40 HP motors	45
Motor Bolts – 50, 60, 75 HP motors	70
Casing Bolts	120
Bowl Bolts	45
Coupling Bolts	28

Liquid Temperature:

Liquid temperature from -13°F (-25°C) to 150°F (65°C)

Note: Pump and piping should be protected from skin contact if temperature is less than 10°C or higher than 40°C

Maximum Working Pressure

Table 4: Maximum Working Pressure

Model	Maximum Pressure	
	175 psi	400 psi
SM1	up to (3) stages	more than (3) stages
SM2	up to (3) stages	more than (3) stages
SM3	up to (3) stages	more than (3) stages
SM4	up to (3) stages	more than (3) stages
SM5	up to (4) stages	more than (4) stages
SM6	up to (4) stages	more than (4) stages

Starts per hour:Table 5: Electric Data²

HP	Motor Frame	RPM	Voltage	Phase	Hz	Start/Hour	
5	182TC	3500	230	1	60	270	
	184TC		230/460	3		165	
7.5	182TC		230	1		3	210
	213TC		230/460	3			150
10	213TC			1		210	
	215TC			3		135	
15	215TC					105	
	20					254TC	150
256TC						75	
25	256TC					135	
	284TSC				30		
30	284TSC		60				
	286TSC		30				
40	286TSC		45				
	324TSC		30				
50	324TSC		45				
	326TSC		25				
60	326TSC		30				
	364TSC		25				
75	364TSC		2				
	365TSC	2					

² Electric data is based on Goulds Pumps' choice motors. Other manufacturer's motors may have different values.

Connections

The following table shows the discharge and suction sizes for each of the SMVT pumps.

Table 6: Pump Connection Sizes

Model and Staging	Suction and Discharge Size
SM1 - up to (3) stages	Standard 3 inch 125# ANSI Flange
SM1 - more than (3) stages	Standard 3 inch 250# ANSI Flange
SM2 - up to (3) stages	Standard 3 inch 125# ANSI Flange
SM2 - more than (3) stages	Standard 3 inch 250# ANSI Flange
SM3 - up to (3) stages	Standard 4 inch 125# ANSI Flange
SM3 - more than (3) stages	Standard 4 inch 250# ANSI Flange
SM4 - up to (3) stages	Standard 4 inch 125# ANSI Flange
SM4 - (4) stage	Standard 4 inch 250# ANSI Flange
SM5 - up to (4) stages	Standard 4 inch 125# ANSI Flange
SM5 - (5) and (6) stage	Standard 4 inch 250# ANSI Flange
SM6 - up to (4) stages	Standard 4 inch 125# ANSI Flange

Noise Level

The noise generated by a pump depends on different factors. Most important are: power, speed and brand name of the motor, whether there is cavitation or not, operating point of the pump, and handling of small quantities of air. A guide value for the sound pressure level measured in dB (A) at a distance of 3 feet from the pump with a 2 pole motor operating at 60 Hz in ideal circumstances with cold water is 78 dB(A) for pumps up to 5 hp, 83 to 85 dB(A) for pumps with motors ranging from 7.5 to 50 hp. For pumps with 4 or 6 pole motors, the value can be decreased with +/- 8 dB(A).

Name Plate Model

The various versions of the SMVT are identified by a product code number on the pump label. This number is also the catalog number for the pump. The meaning of each digit in the product code number is shown in the Appendix. Not all combinations are possible; consult your Goulds Pumps distributor for specific requirements.

Performance

Performance curves for your Goulds model SMVT may be found in the selection program available on www.goulds.com. The correct performance curve can be determined from the name plate model number as defined above. You will need to know the pump model number.

IV. Installation

Description

This section covers the general information and cautions about installing your pump as well as specific steps to take during installation.

Location

Locate the pump as near to the liquid source as practical and below the level of the liquid for automatic self priming. If the pump must be above the liquid source, a foot valve must be provided on the suction pipe.

Allow adequate space around the pump for servicing and ventilation.

Protect the pump and piping from freezing temperatures.

Provide other weather protection consistent with the motor enclosure rating. The maximum ambient temperature for the pump is 40°C (104°F).

For installation at altitudes greater than 3,000 feet, the pump selection should be de-rated due to the difference in barometric pressure. Contact your Goulds distributor for assistance in selection.

Foundation

The unit must be securely affixed to a leveled concrete or metal base foundation that is adequate to absorb vibration and to provide permanent, rigid support for the pump and motor assembly. If the unit is to be installed on a concrete foundation, hold down bolts should be sunk in concrete and aligned with the holes in the feet. When the concrete has dried, tighten nuts to keep the pump firmly in position.

Your SMVT pump has been supplied with a rigid base pump body with two feet. The mounting dimensions are shown in Figure 2.

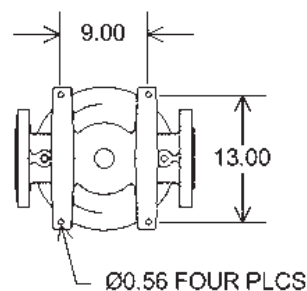

Figure 2: Base Mounting Dimensions

Installation of Mechanical Seal to Pump Assembly

Your SMVT pump has been shipped with the pump assembly and mechanical seal disassembled.

1. Remove the (2) coupling guards.
2. Lubricate the inside of the mechanical seal assembly (supplied with pump) with STP or Dow-Corning #4 grease. Be sure that there is an o-ring at the back of the gland flange.
3. Take care to make sure that the pump shaft is clean; it should be free of all burrs, oil, and grease. The pump shaft should be completely dry before moving on to the next step.

4. To install the mechanical seal assembly, carefully slide it down the pump shaft until the gland contacts the mounting surface on the top of the seal housing.
5. Install the (4) hex head bolts on the seal gland to the seal housing. See the “Engineering Data” section on page 8 of this manual for the proper torque value.
6. Move on to the next section; “Installation of Motor to Pump Assembly”.

Installation of Motor to Pump Assembly

Your SMVT pump has been shipped with the pump assembly and motor disassembled.

1. With an adequately sized crane carefully lower the motor assembly onto the motor adapter located on the top of the pump.
2. Secure the motor to the motor adapter with the (4) hex head bolts supplied with pump. See the “Engineering Data” section on page 8 of this manual for the proper torque value.
3. Disassemble the coupling (supplied with pump) by removing the (6) socket head screws and machine washers between the coupling halves (see Figure 3). Retain bolts and dowel pin for reassembly.

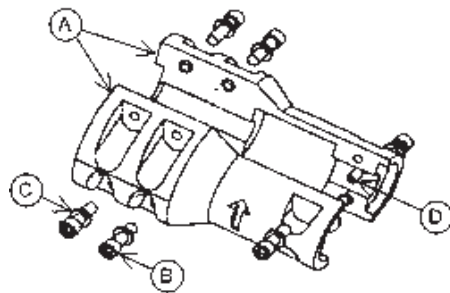

Figure 3: Motor Coupling

Item	Quantity	Description
A	2	Coupling Half
B	6	Socket Head Cap Screw
C	6	Lock-washer
D	1	Dowel Pin

4. Take care to make sure that the pump and motor shafts are clean; they should be free of all burrs, oil, and grease. Both the pump and motor shafts should be completely dry before moving on to the next step.
5. Install the dowel pin on the pump shaft and loosely assemble the shaft coupling. Do not tighten the coupling at this point; it should be left loose enough to receive the motor shaft in the following section.
6. Insert the impeller shim (supplied with the pump) between the shaft coupling and seal gland. This will lift the shaft/impellers to the running position.
7. Very lightly tighten the (2) socket head cap screws on the pump end of the coupling (refer to Figure 4). Tighten the coupling evenly; ensure that the coupling is symmetrical on both the pump and motor shafts. Do NOT torque the cap screws in this step.

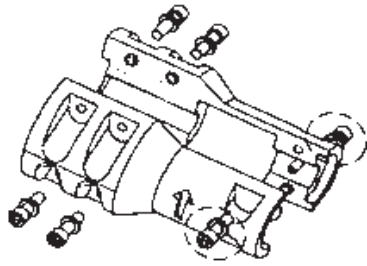

Figure 4: Coupling Socket Head Screws

8. Very lightly tighten the remaining (4) socket head screws on the coupling. Tighten the coupling evenly; ensure that the coupling is symmetrical on both the pump and motor shafts. Do NOT torque the cap screws in this step.
9. Torque the socket head cap screws on the coupling. Refer to Figure 5 for the proper torque pattern. See the “Engineering Data” section on page 8 of this manual for the proper torque value.

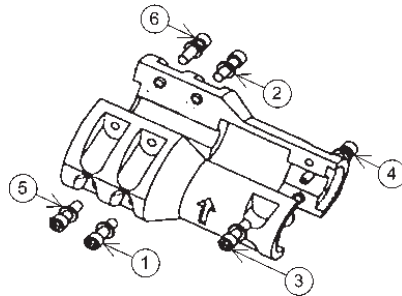

Figure 5: Coupling Torque Pattern

10. Remove the impeller shim and retain for future use.
11. Tighten the set screws on the seal gland. See the “Engineering Data” section on page 8 of this manual for the proper torque value.
12. Install the (2) coupling guards.

Piping

General: Guidelines for piping are given in the “Hydraulic Institute Standards” and should be reviewed prior to installation.



Warning: Never draw piping into place by using force on the suction and discharge connections of the pump. This may impose dangerous strains on the unit causing misalignment, poor operation and physical injury and damage to the equipment.

1. All piping must be supported independently of and line up naturally with the pump suction and discharge. It MUST NOT place piping loads on the pump.
2. Piping should be no smaller than the pump’s suction and discharge connections and kept as short as possible, with minimal fittings to minimize friction losses.
3. DO NOT connect piping to pump until pump and/or driver are securely fastened to a supporting structure.
4. When pumping liquids at elevated temperatures, it is recommended that expansion loops or joints be used in the suction and discharge piping. Refer to Figure 6 for correct placement to avoid pump strain or misalignment due to linear expansion of piping.

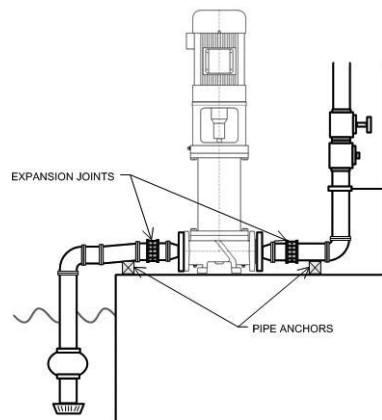

Figure 6: Correct Placement of Expansion Joint

5. The piping should be arranged to permit pump isolation on both the suction and discharge sides so that the pump can be drained during maintenance and repair.
6. Carefully clean all pipe parts, valves and fittings and pump branches prior to assembly.
7. All pipe joints MUST be airtight.
8. Proper placement of any temperature probes should be at the top end of the pump unit casing in one of the provided ports. Ports will come from factory plugged. Proper temperature probe location is shown in Figure 7.

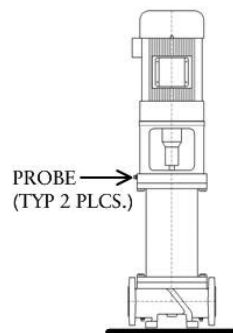

Figure 7: Correct Placement of Temperature Probes

Suction Piping



Warning: NPSH available must always exceed NPSH required by the pump. For suction lifts over 10 feet and liquid temperatures over 120 degrees Fahrenheit, consult the performance curve for your pump to determine NPSH required.

Properly installed suction piping is a necessity for trouble-free pump operation. Suction piping should be flushed BEFORE connection to the pump.

1. Use of elbows close to pump suction should be avoided. There should be a minimum of two pipe diameters of straight pipe between elbow and suction inlet (Reference Figure 8). All elbows should be long-radius.

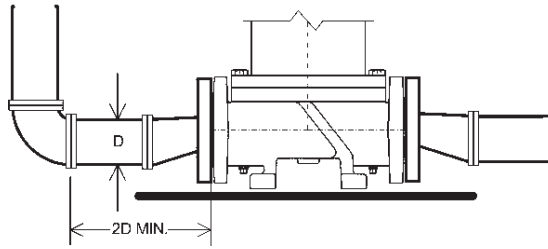

Figure 8: Piping Elbows

2. Use suction pipe that is one or two sizes larger than the pump suction with a reducer at the suction. Suction piping should never be smaller diameter than the pump suction.
3. Reducers should be eccentric at the pump suction with sloping side down and horizontal side at the top (Reference Figure 9).

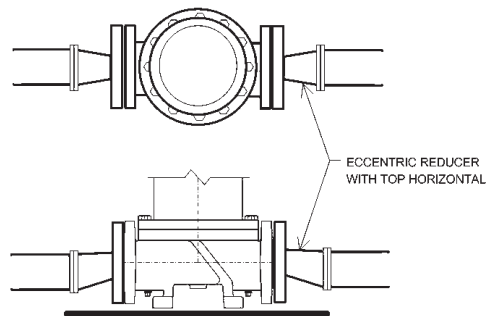

Figure 9: Eccentric Reducer

4. Suction strainers, when used, must have a net “free area” of at least three times the suction pipe area.
5. Separate suction lines are recommended when more than one pump is operating from the same source or supply.

Suction Lift Conditions

If pump is to be installed above the liquid source, the following **MUST** be provided:

1. No part of the suction piping can be above the pump suction (to avoid air pockets).
2. Suction piping must slope upwards to the pump on any horizontal pipe sections.
3. All joints **MUST** be airtight.
4. A means of maintaining prime during intermittent duty, such as a foot valve, must be provided.
5. The suction strainer or suction bell **MUST** be at least three times the diameter of the suction.
6. Ensure that the size and minimum submergence over the suction inlet is sufficient to prevent air from entering the pump through a suction vortex. See typical intake piping arrangements in Figures 10-13.

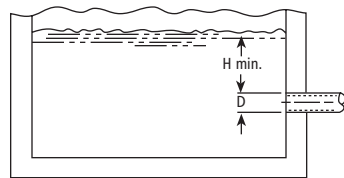

Figure 10

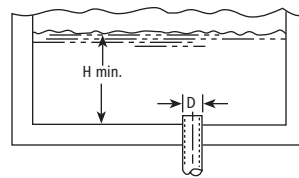

Figure 11

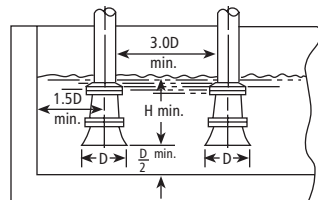

Figure 12

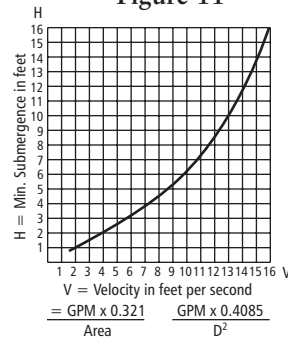

Figure 13

Figures 10-13: Typical Piping Arrangements

Suction Head (Flooded Suction) Conditions

If pump is to be installed below the liquid source, the following **MUST** be provided:

1. An isolation valve should be installed in the suction line at least two pipe diameters from the pump suction to permit closing the line for pump maintenance.



WARNING: Do not use the isolation/gate valve to throttle the pump as this may cause loss of prime, excessive temperatures and damage to pump, voiding warranty.

2. Keep suction pipe free from air pockets.
3. Piping should be level or slope gradually downward from the source of supply.
4. No portion of the piping should extend below pump suction.
5. The size of the entrance from the supply should be one or two sizes larger than the suction pipe.
6. The suction pipe must be adequately submerged below the liquid surface to prevent vortices and air entrainment at the supply. See above illustrations.

Discharge Piping

1. Isolation and check valves should be installed in the discharge line. Locate the check valve between the isolation valve and the pump. This will permit inspection of the check valve. The isolation valve is required for priming, regulation of flow and for inspection and maintenance of the pump. The check valve prevents pump or seal damage due to reverse flow through the pump when the driver is off.
2. Increasers, if used, should be placed between the pump and check valves.
3. Cushioning devices should be used to protect the pump from surges and water hammer if quick closing valves are installed in the system.

Typical Plumbing and Installation

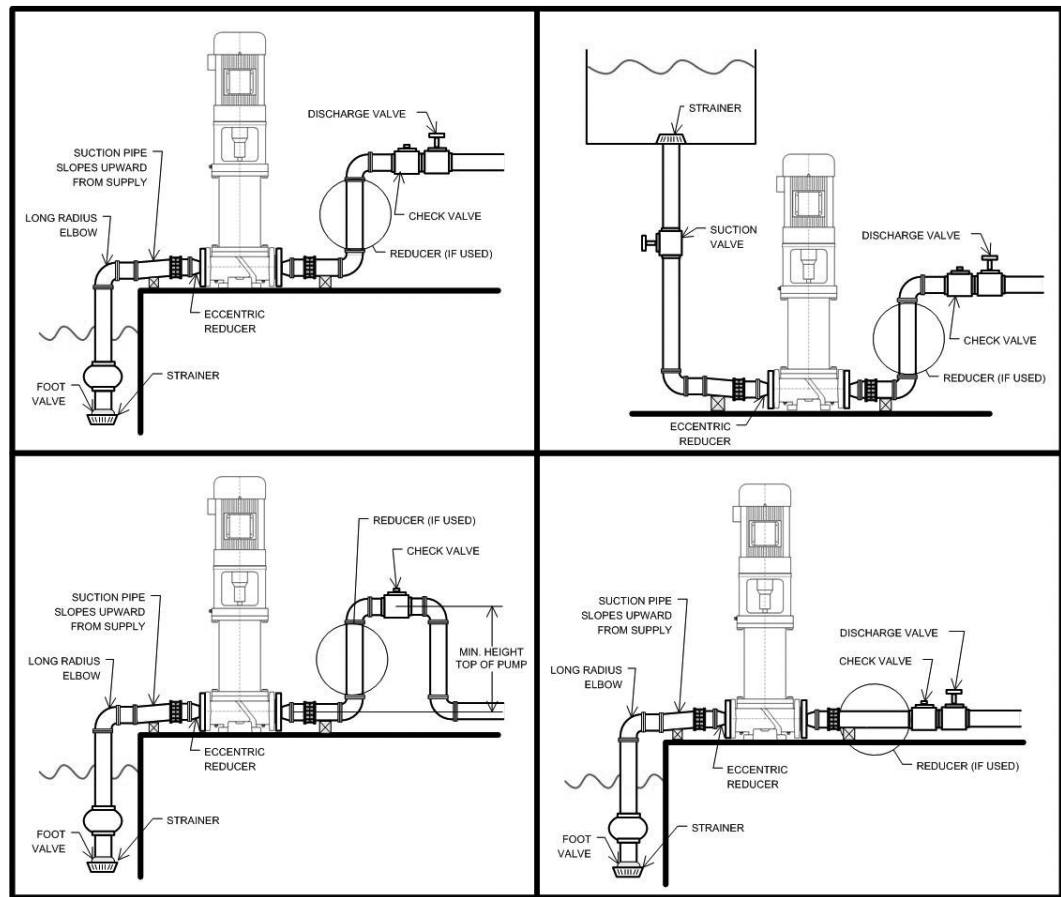

Figure 14: Typical Plumbing and Installation

Final Piping Check

After connecting the piping to the pump, rotate the motor shaft to make sure that there is no binding.

Wiring



Warning: DISCONNECT AND LOCKOUT ELECTRICAL POWER BEFORE INSTALLING OR SERVICING PUMP.



Warning: Install ground and wire according to local and National Electrical Code requirements.



Warning: Install an all leg electrical power disconnect switch near the pump.



Warning: Electrical supply MUST match motor's nameplate specifications. Incorrect voltage can cause fire, damage the motor and void the warranty.



Warning: Motors without built-in protection **MUST** be provided with contactors and thermal overloads for single phase motors, or starters with heaters for three phase motors. See motor nameplate.



Warning: Motors equipped with automatic thermal protectors open the motor's electrical circuit when an overload exists. This can cause the pump to start unexpectedly and without warning.

- Use only stranded copper wire to motor and ground.
- Wire size **MUST** limit the maximum voltage drop to 10% of the motor nameplate voltage at the motor terminals.
- The ground wire **MUST** be at least as large as the wire to the motor.
- Wires should be color coded for ease of maintenance.
- Follow motor manufacturer's wiring diagram on the motor nameplate or terminal cover carefully.
- Three phase motors require all-leg protection with properly sized magnetic starters and thermal overloads.



Warning: Failure to permanently ground the pump, motor and controls before connecting to electrical power can cause shock, burns or death.

Connect the electrical leads to the motor as follows:

Single Phase Motors

1. Connect the **BLACK** wire to the **BLACK** motor lead.
2. Connect the **WHITE** wire to the **WHITE** motor lead.
3. Connect the **GREEN** wire to the **GREEN** motor lead.

Three Phase Motors

See Figure 15 for three-phase wiring diagrams.

Figure 15: Three Phase Motor Wiring Diagram

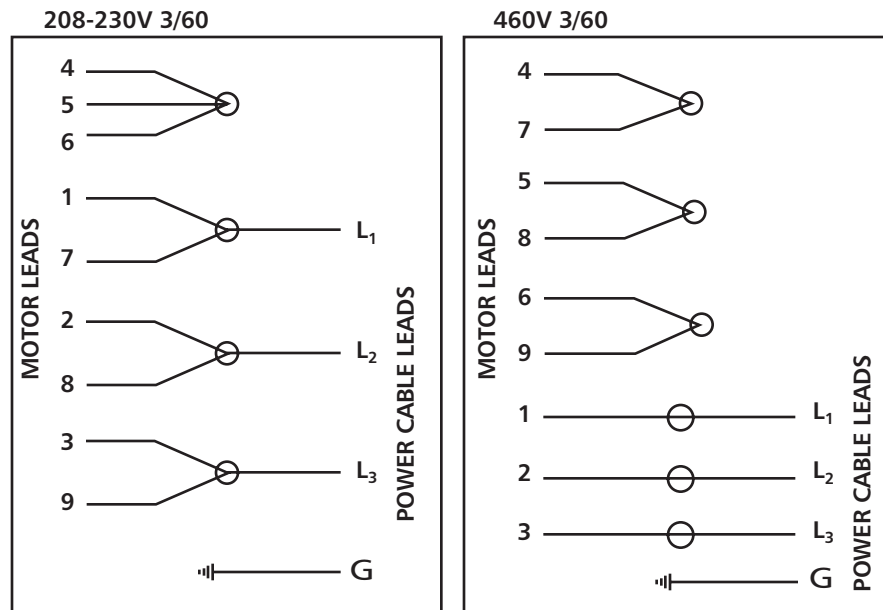

Rotation

Notice: Incorrect rotation may cause damage to the pump and voids the warranty.

- Correct rotation is right-hand, clockwise when viewed from the motor end.
- Check rotation by observing the motor fan or the coupling THROUGH the coupling guard. DO NOT confuse the rotation direction with the flow arrows cast into the pump body. The rotation arrow is cast into the coupling.
- To reverse three phase motor rotation, have a qualified technician interchange any two of the three power supply leads.

V. Commissioning, Startup, Operation and Shutdown

Overview

This section covers the basic procedures to use in preparing your pump for startup, starting, operating and shutting it down. **DO NOT CONTINUE UNTIL ALL PARTS OF THE INSTALLATION PROCESS (SECTION IV) HAVE BEEN COMPLETED.**

Priming

Never start the pump until it has been properly primed. Several different methods of priming can be used, depending upon type of installation and service involved.



Warning: SMVT pumps are not self priming and must be fully primed at all times during operation. Loss of prime can lead to excessive heat and severe damage to the pump and seal.

Suction Lift (Liquid below Pump Suction):

1. Install a foot valve at suction end.
2. Remove the vent plug. See Figure 16.
3. With a vented funnel, completely fill the casing with liquid at the vent plug opening.
4. Re-install the vent plug.
5. Open the suction valve.

Flooded suction (Liquid above Pump Suction):

1. Close the discharge valve.
2. Remove the vent plug. See Figure 16.

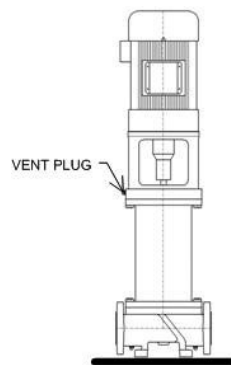

Figure 16: Vent/Drain Plug Locations

3. Slowly open the suction valve until liquid flows out of the vent plug opening.
4. Re-install the vent plug.
5. Open the discharge valve.

Precautions

Warning: Do not operate units without safety guards in place or severe personal injury may result.



Warning: Splashing or immersing open drip proof motors in fluid can cause fire, shock, burns or death. Make sure motor guards are in place.

Starting

1. Make sure suction valve and any recirculation or cooling lines are open.
2. Fully close or partially open discharge valve as dictated by system conditions.
3. Start driver.



Warning: DO NOT operate unit without safety guards in place. To do so could result in severe personal injury or death.



Caution: Immediately observe pressure gauges. If discharge pressure is not quickly attained, stop driver, re-prime and attempt to restart.

4. Slowly open discharge valve until the desired flow is obtained.



Caution: Observe pump for vibration levels, bearing temperature and excessive noise. If normal levels are exceeded, shut down and resolve.

5. After stabilizing the system at normal operating conditions, check the piping and adjust supports if needed.

Operation**General considerations:**

Caution: Always vary capacity with regulating valve in the discharge line. Never throttle flow from the suction side.



Caution: Driver may overload if the pumpage specific gravity (density) or viscosity is greater than originally assumed or the rated flow rate is exceeded.



Caution: Always operate the pump at or near the rated conditions to prevent damage resulting from cavitation or recirculation.

Operating at reduced capacity:



Warning: DO NOT operate pump below minimum rated flows or with suction and or discharge valve closed. These conditions may create an explosive hazard due to vaporization of pumpage and can quickly lead to pump failure, physical injury or property damage.



Caution: Damage can occur from:

1. Increased vibration levels – affects bearings and mechanical seal.
 2. Increased radial loads – Stresses on shaft and bearings.
 3. Heat build-up – Vaporization causing rotating parts to score or seize.
 4. Cavitation – Damage to internal surfaces of pump.
-

Operating under Freezing Conditions

Exposure to freezing conditions while pump is idle could cause liquid to freeze and damage the pump. Liquid inside the pump should be drained.

Shutdown

1. Slowly close the discharge valve.
2. Shut down and lock the driver to prevent accidental rotation.



Warning: When handling hazardous and or toxic fluids, proper personal protective equipment should be worn. If pump is being drained, precautions must be taken to prevent physical injury. Pumpage must be handled and disposed of in conformance with applicable environmental regulations.

VI. Maintenance

Overview

This section covers the procedures, precautions and schedule for maintenance of your Goulds pump. A routine maintenance program can extend the life of your pump. Well maintained equipment will last longer and require fewer repairs.

Warnings



Failure to disconnect and lockout electrical power before attempting any maintenance can cause shock, burns or death.



Failure to relieve system pressure and drain system before attempting any maintenance can cause property damage, personal injury or death.



If piping is hazardous or toxic fluids, system must be flushed prior to performing service involving liquid end disassembly.

Maintenance Schedule

Inspection intervals should be shortened appropriately if the pumpage is abrasive or corrosive, or if the environment is classified as potentially explosive.

Routine Maintenance

- Motor Maintenance
- Seal monitoring
- Vibration analysis
- Discharge pressure
- Temperature monitoring

Routine Inspections

- Check for unusual noise, vibration and bearing temperatures
- Inspect pump and piping for leaks
- Check static seal leakage
- Mechanical seal: should be no leakage

3 Month Inspections

- Check the foundation and hold-down bolts for tightness.
- If the pump has been left idle, check the seal and replace if needed.

Annual Inspections

- Check the pump capacity, pressure and power. If pump performance does not satisfy your process requirements and the process requirements have not changed, the pump should be disassembled; inspected and worn parts should be replaced. Otherwise, a system inspection should be done.

Motor Maintenance

Consult the motor manufacturer's Installation, Operation, and Maintenance manual supplied with your motor for proper maintenance procedure and schedule.

General Disassembly

Required Tools: The following tools should be available for use during pump disassembly and assembly. Wrenches, lifting sling, rubber mallet, torque wrench with sockets, non-corrosive cleaning agents, and impeller shim (supplied with pump).



Warning: Lock out power supply to driver motor to prevent accidental startup and physical injury.



Warning: Pump components can be heavy. Proper methods of lifting must be employed to avoid physical injury and/or equipment damage. Steel toed shoes must be worn at all times.



Warning: The pump may handle hazardous and/or toxic fluids. Proper personal protective equipment should be worn. Precautions must be taken to prevent physical injury. Pumpage must be handled and disposed of in conformance with applicable environmental regulations.



Warning: Allow all system and pump components to cool before handling them to prevent physical injury.

Note: Before disassembling the pump for overhaul, ensure all replacement parts are available.

Mechanical Seal Replacement



Warning: Lock out power supply to driver motor to prevent accidental startup and physical injury.



Warning: Pump components can be heavy. Proper methods of lifting must be employed to avoid physical injury and/or equipment damage. Steel toed shoes must be worn at all times.



Warning: The pump may handle hazardous and/or toxic fluids. Proper personal protective equipment should be worn. Precautions must be taken to prevent physical injury. Pumpage must be handled and disposed of in conformance with applicable environmental regulations.



Warning: Allow all system and pump components to cool before handling them to prevent physical injury.

Note: Before disassembling the pump for overhaul, ensure all replacement parts are available.

1. Close all necessary suction and discharge valves.
2. Drain the liquid from the pump by removing the lower drain plugs and the upper vent plug. See Figure 17.

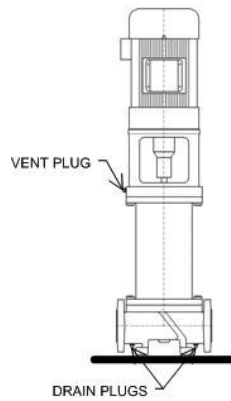

Figure 17: Vent/Drain Plug Locations

3. Remove the (2) coupling guards.
4. Disassemble the coupling by removing the (6) socket head screws. Remove the dowel pin on the pump shaft. See Figure 18. Retain bolts and dowel pin for reassembly.

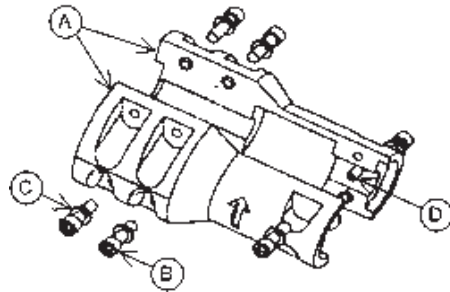

Figure 18: Motor Coupling

Item	Quantity	Description
A	2	Coupling Half
B	6	Socket Head Cap Screw
C	6	Lock-washer
D	1	Dowel Pin

5. Loosen the set screws on the seal collar.
6. Remove the (4) hex head cap screws on the seal gland. Retain bolts for reassembly.
7. Carefully lift the entire seal assembly from the seal housing by sliding it up the pump shaft. Discard the entire seal assembly.
8. Lubricate the inside of the new mechanical seal assembly with STP or Dow-Corning #4 grease. Be sure that there is an o-ring at the back of the gland flange.
9. Take care to make sure that the pump shaft is clean; it should be free of all burrs, oil, and grease. The pump shaft should be completely dry before moving on to the next step.
10. To install the new mechanical seal assembly, carefully slide it down the pump shaft until the gland contacts the mounting surface on the top of the seal housing.
11. Install the (4) hex cap screws on the seal gland to the seal housing. See the “Engineering Data” section on page 8 of this manual for the proper torque value.

12. Take care to make sure that the pump and motor shafts are clean; they should be free of all burrs, oil, and grease. Both the pump and motor shafts should be completely dry before moving on to the next step.
13. Install the dowel pin on the pump shaft and loosely assemble the shaft coupling. Do not tighten the coupling at this point; it should be left loose enough to set the running position in the next step.
14. Insert the impeller shim (supplied with the pump) between the shaft coupling and seal gland. This will lift the shaft/impellers to the running position.
15. Very lightly tighten the (2) socket head cap screws on the pump end of the coupling (refer to Figure 19). Tighten the coupling evenly; ensure that the coupling is symmetrical on both the pump and motor shafts. Do NOT torque the cap screws in this step.

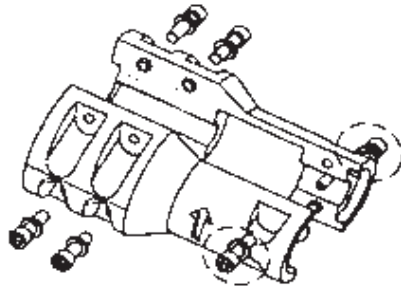

Figure 19: Coupling Socket Head Screws

16. Very lightly tighten the remaining (4) socket head screws on the coupling. Tighten the coupling evenly; ensure that the coupling is symmetrical on both the pump and motor shafts. Do NOT torque the cap screws in this step.
17. Torque the socket head cap screws on the coupling. Refer to Figure 20 for the proper torque pattern. See the “Engineering Data” section on page 8 of this manual for the proper torque value.

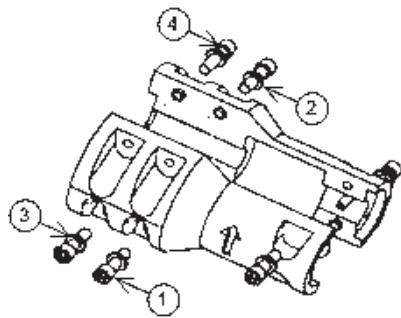

Figure 20: Coupling Torque Pattern

18. Remove the impeller position shim. Retain for later use.
19. Tighten the set screws on the seal gland. See the “Engineering Data” section on page 8 of this manual for the proper torque value.
20. Install the (2) coupling guards.
21. Follow the instructions in “Section V. Commissioning, Startup, Operation, and Shutdown” for the proper procedures to restart the pump.

Motor Replacement

1. Remove the (2) coupling guards.
2. Loosen the set screws on the seal gland.
3. Disassemble the coupling by removing the (6) socket head screws. Remove the dowel pin on the pump shaft. See Figure 21. Retain bolts and dowel pin for reassembly.

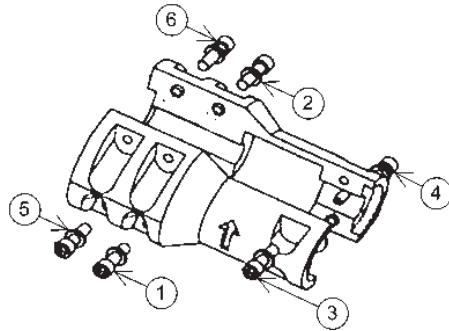

Figure 21: Motor Coupling

Item	Quantity	Description
A	2	Coupling Half
B	6	Socket Head Cap Screw
C	6	Lock-washer
D	1	Dowel Pin

4. Remove the (4) hex head bolts the join the motor and motor adapter. Retain bolts for reassembly.
5. With an adequately sized crane carefully remove the motor assembly.
6. With an adequately sized crane carefully lower the new motor assembly onto the motor adapter located on the top of the pump.
7. Secure the motor with the (4) hex head bolts. See the “Engineering Data” section on page 8 of this manual for the proper torque value.
8. Take care to make sure that the pump and motor shafts are clean; they should be free of all burrs, oil, and grease. Both the pump and motor shafts should be completely dry before moving on to the next step.
9. Install the dowel pin on the pump shaft and loosely assemble the shaft coupling. Do not tighten the coupling at this point; it should be left loose enough to receive the motor shaft in the following section.
10. Insert the impeller shim (supplied with the pump) between the shaft coupling and seal gland. This will lift the shaft/impellers to the running position.
11. Very lightly tighten the (2) socket head cap screws on the pump end of the coupling (refer to Figure 22). Tighten the coupling evenly; ensure that the coupling is symmetrical on both the pump and motor shafts. Do NOT torque the cap screws in this step.

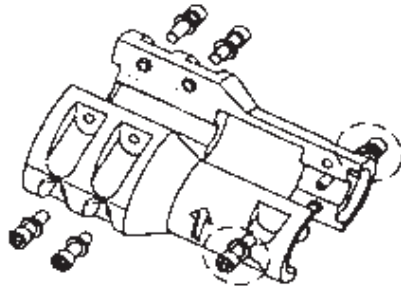

Figure 22: Coupling Socket Head Screws

12. Very lightly tighten the remaining (4) socket head screws on the coupling. Tighten the coupling evenly; ensure that the coupling is symmetrical on both the pump and motor shafts. Do NOT torque the cap screws in this step.
13. Torque the socket head cap screws on the coupling. Refer to Figure 23 for the proper torque pattern. See the “Engineering Data” section on page 8 of this manual for the proper torque value.

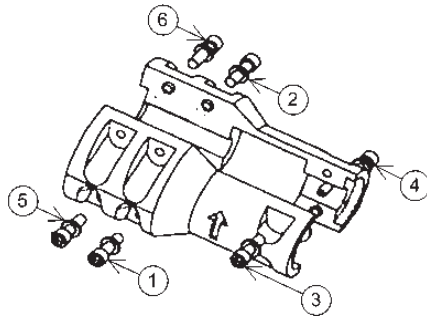

Figure 23: Coupling Torque Pattern

14. Remove the impeller shim and retain for future use.
15. Tighten the set screws on the seal gland. See the “Engineering Data” section on page 8 of this manual for the proper torque value.
16. Install the (2) coupling guards.
17. Follow the instructions in “Section IV. Installation” to properly wire the motor.
18. Follow the instructions in “Section V. Commissioning, Startup, Operation, and Shutdown” for the proper procedures to restart the pump.

Pump Disassembly Instructions and Internal Stack Replacement



Warning: Lock out power supply to driver motor to prevent accidental startup and physical injury.



Warning: Pump components can be heavy. Proper methods of lifting must be employed to avoid physical injury and/or equipment damage. Steel toed shoes must be worn at all times.



Warning: The pump may handle hazardous and/or toxic fluids. Proper personal protective equipment should be worn. Precautions must be taken to prevent physical injury. Pumpage must be handled and disposed of in conformance with applicable environmental regulations.



Warning: Allow all system and pump components to cool before handling them to prevent physical injury.

Note: Before disassembling the pump for overhaul, ensure all replacement parts are available.

1. Close all necessary suction and discharge valves.
2. Drain the liquid from the pump by removing the lower drain plugs and the upper vent plug. See Figure 24.

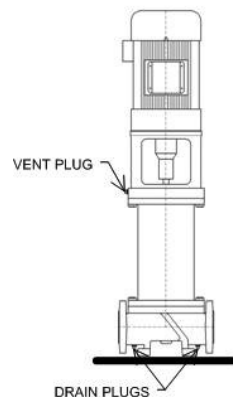

Figure 24: Vent/Drain Plug Locations

3. Remove the (2) coupling guards.
4. Loosen the set screws on the seal collar.
5. Disassemble the coupling by removing the (6) socket head screws. Remove the dowel pin on the pump shaft. See Figure 25. Retain bolts and dowel pin for reassembly.

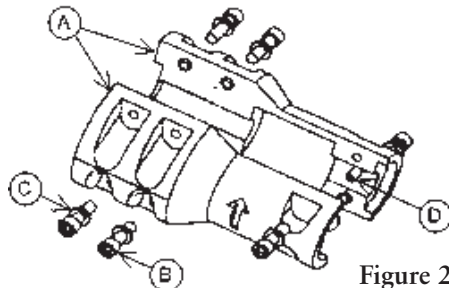

Figure 25: Motor Coupling

Item	Quantity	Description
A	2	Coupling Half
B	6	Socket Head Cap Screw
C	6	Lock-washer
D	1	Dowel Pin

6. Remove the (4) hex head bolts the join the motor and motor adapter. Retain bolts for reassembly.
7. With an adequately sized crane carefully remove the motor assembly.
8. Remove the (4) hex head bolts on the seal gland. Retain bolts for reassembly.
9. Carefully lift the entire seal assembly from the seal housing by sliding it up the pump shaft. Retain the seal assembly for pump reassembly.
10. Remove the (12) upper casing bolts. See Figure 26. Retain bolts for reassembly.



Figure 26: Upper Casing Bolts

11. With an adequately sized crane carefully lift the internal stack from the pump casing. Lift from the motor adapter as shown on page 7 of this manual. The motor adapter, seal plate, pump shaft, and cartridge stack will lift as a complete unit.
12. Carefully set the cartridge stack removed from the pump so that the stack is supported and the seal plate is accessible.
13. Remove the (6) bowl bolts that connect the upper bowl of the cartridge stack to the seal plate. The seal plate and motor adapter can be removed as a single unit. Retain bolts for reassembly.
14. Assemble the seal plate/motor adapter to the replacement cartridge stack using the (6) bowl bolts removed in step 13. Torque the bolts in the pattern shown in Figure 27. See the “Engineering Data” section on page 8 of this manual for the proper torque value.

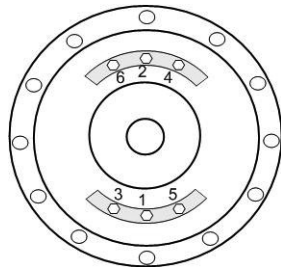

Figure 27: Bowl Bolts Torque Pattern

15. Install a new o-ring on the lower suction cover of the replacement cartridge stack.
16. Remove the old o-ring on the upper flange of the pump casing and discard. Install a new o-ring on the upper flange of the pump casing.
17. With an adequately sized crane carefully lift the replacement stack. Lift from the motor adapter as shown on page 7 of this manual. The motor adapter, seal plate, pump shaft, and cartridge stack will lift as a complete unit.
18. Carefully lower the replacement stack approximately halfway into the pump casing. Align the motor adapter windows to the desired orientation.
19. VERY slowly and carefully continue to lower the replacement stack into the pump casing. As the seal plate approaches the upper flange of the pump casing, take care to align the bolt circles of the pump casing and seal plate.
20. Smoothly guide the replacement stack so that the lower suction cover engages the pump body. Be careful to avoid damaging the lower o-ring, as this will affect the pump performance.
21. Install the (12) upper casing bolts 'finger-tight'.
22. Torque the (12) upper casing bolts in the pattern shown in Figure 28. See the "Engineering Data" section on page 8 of this manual for the proper torque value.

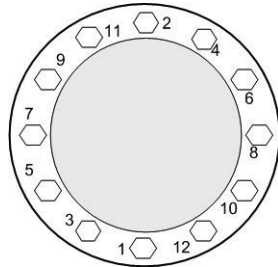

Figure 28: Upper Casing Bolts Torque Pattern

23. Lubricate the inside of the mechanical seal assembly with STP or Dow-Corning #4 grease. Be sure that there is an o-ring at the back of the gland flange.
24. Take care to make sure that the pump shaft is clean; it should be free of all burrs, oil, and grease. Pump shaft should be completely dry before moving on to the next step.
25. To install the mechanical seal assembly, carefully slide it down the pump shaft until the gland contacts the mounting surface on the top of the seal housing.
26. Install the (4) hex cap screws on the seal gland to the seal housing. See the "Engineering Data" section on page 8 of this manual for the proper torque value.
27. With an adequately sized crane carefully lower the motor assembly onto the motor adapter located on the top of the pump. Allow the motor shaft to engage into the coupling. Be careful not to damage the motor shaft.
28. Secure the motor to the motor adapter with the (4) hex head bolts removed in step 6 of this section. See the "Engineering Data" section on page 8 of this manual for the proper torque value.
29. Take care to make sure that the pump and motor shafts are clean; they should be free of all burrs, oil, and grease. Both the pump and motor shafts should be completely dry before moving on to the next step.
30. Install the dowel pin on the pump shaft and loosely assemble the shaft coupling. Do not tighten the coupling at this point; it should be left loose enough to receive the motor shaft in the following section.

31. Insert the impeller shim (supplied with the pump) between the shaft coupling and seal gland. This will lift the shaft/impellers to the running position.
32. Very lightly tighten the (2) socket head cap screws on the pump end of the coupling (refer to Figure 29). Tighten the coupling evenly; ensure that the coupling is symmetrical on both the pump and motor shafts. Do NOT torque the cap screws in this step.

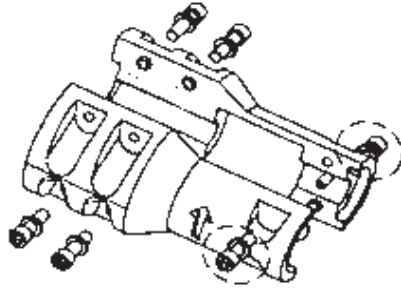

Figure 29: Coupling Socket Head Screws

33. Very lightly tighten the remaining (4) socket head screws on the coupling. Tighten the coupling evenly; ensure that the coupling is symmetrical on both the pump and motor shafts. Do NOT torque the cap screws in this step.
34. Torque the socket head cap screws on the coupling. Refer to Figure 30 for the proper torque pattern. See the “Engineering Data” section on page 8 of this manual for the proper torque value.

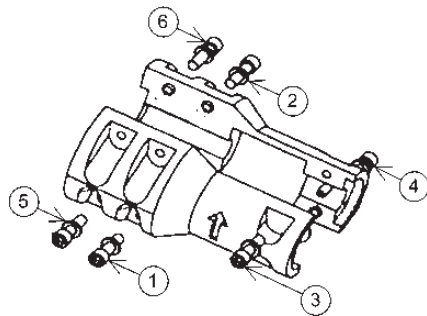

Figure 30: Coupling Torque Pattern

35. Remove the impeller shim and retain for future use.
36. Tighten the set screws on the seal gland. See the “Engineering Data” section on page 8 of this manual for the proper torque value.
37. Install the (2) coupling guards.
38. Follow the instructions in “Section IV. Installation” to properly wire the motor.
39. Follow the instructions in “Section V. Commissioning, Startup, Operation, and Shutdown” for the proper procedures to restart the pump.

VII. Troubleshooting



Failure to disconnect and lockout electrical power before attempting any maintenance can cause shock, burns or death.

Symptoms

MOTOR NOT RUNNING

(See Probable Causes 1 through 5)

LITTLE OR NO LIQUID BEING DELIVERED BY PUMP

(See Probable Causes 6 through 12)

POWER CONSUMPTION TOO HIGH

(See Probable Causes 3, 12, 13, 15)

EXCESSIVE NOISE AND VIBRATION

(See Probable Causes 3, 6-8, 10, 12, 13, 16)

PROBABLE CAUSE

1. Motor thermal protector tripped.
2. Open circuit breaker or blown fuse.
3. Impellers binding.
4. Motor improperly wired.
5. Defective Motor.
6. Pump is not primed, air or gas in liquid.
7. Discharge or suction plugged, or valve closed.
8. Incorrect rotation (three-phase only)
9. Low voltage or phase loss.
10. Impellers worn or plugged.
11. System head too high.
12. NPSHa too low-excessive suction lift or losses.
13. Discharge head too low-excessive flow rate.
14. Fluid viscosity, specific gravity too high.
15. Worn bearing.
16. Pump, motor or piping loose.

VIII. Appendix

SMVT Product Line Numbering System

The various versions of the SMVT line are identified by a product code number on the pump label. This number is also the catalog number for the pump. The meaning of each digit in the product code number is shown below. **Note:** Not all combinations are possible. Consult your Goulds Pumps distributor.

Example Product Code: 3SMA1J2C1VA

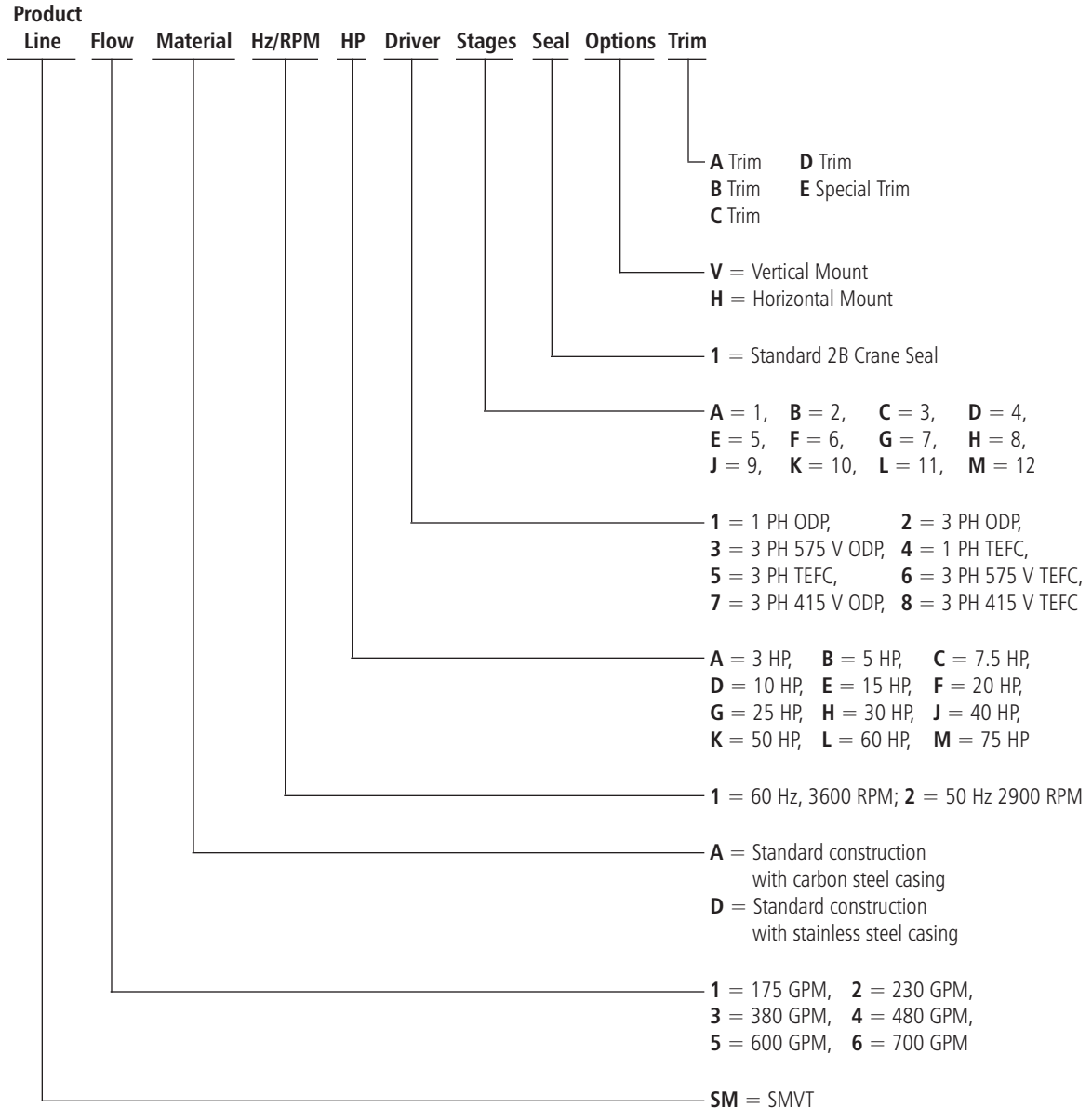

Sectional Pump Assembly

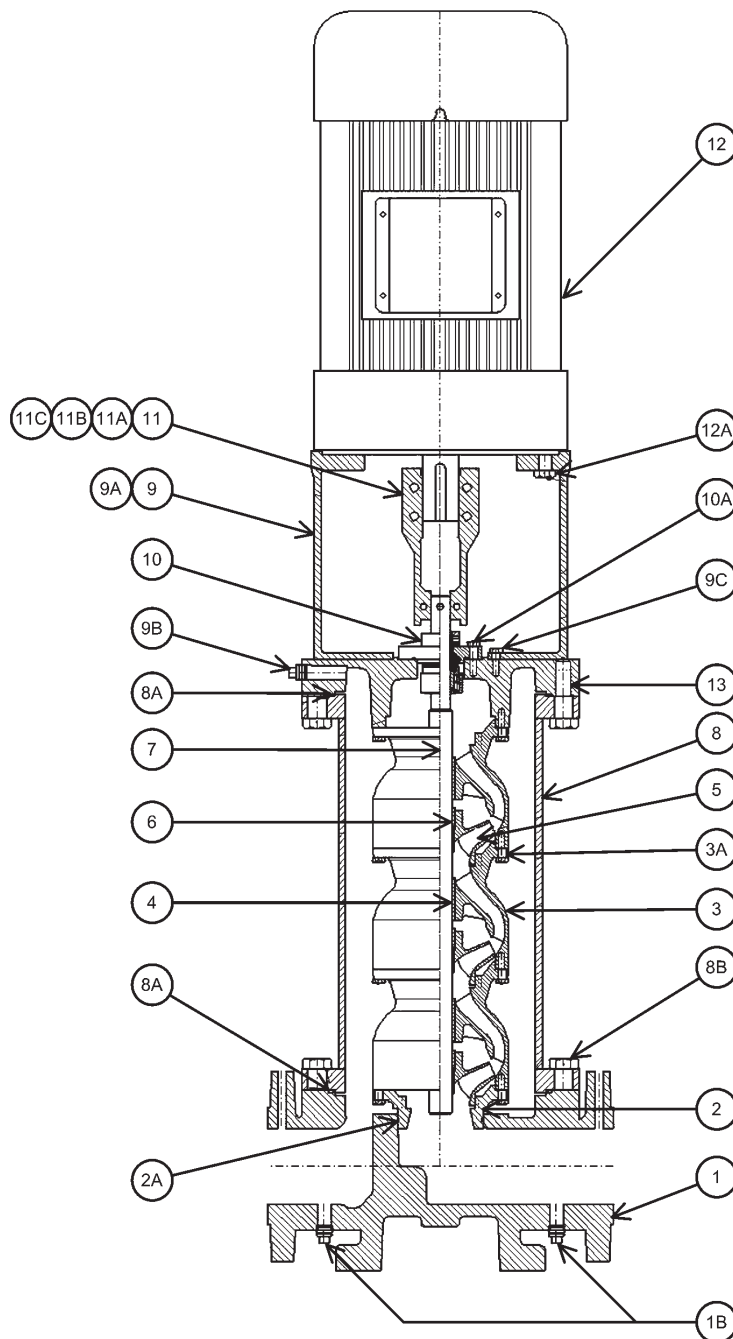

Item No.	Description
1	Pump Body
1B	Pipe Plug – Drain
2	Suction Cover
2A	O-Ring – Suction Cover
3	Intermediate Bowl
3A	Hex Screws – Bowl
4	Bearing
5	Impeller
6	Taperlock
7	Shaft
8	Casing
8A	O-Ring – Casing
8B	Hex Screws – Casing
9	Motor Support
9A	Guard – Motor Support
9B	Pipe Plug
9C	Hex Screws – Motor Support
10	Mechanical Seal
10A	Hex Screws – Seal
11	Coupling
11A	Cap Screws – Coupling
11B	Lock Washers – Coupling
11C	Dowel Pin – Coupling
12	Motor
12A	Hex Screws – Motor
13	Seal Plate

Notes

Notes

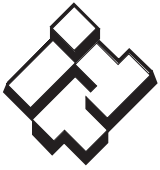

ITT

Commercial Water

WARRANTY

WARRANTY – Company warrants title to the product(s) and, except as noted with respect to items not of Company's manufacturer, also warrants the product(s) on date of shipment to Purchaser, to be of the kind and quality described herein, and free of defects in workmanship and material. THIS WARRANTY IS EXPRESSLY IN LIEU OF ALL OTHER WARRANTIES, INCLUDING BUT NOT LIMITED TO IMPLIED WARRANTIES OF MERCHANTABILITY AND FITNESS, AND CONSTITUTES THE ONLY WARRANTY OF COMPANY WITH RESPECT TO THE PRODUCT(S).

If within one year from date of initial operation, but not more than 18 months from date of shipment by Company of any item of product(s), Purchaser discovers that such item was not as warranted above and promptly notifies Company in writing thereof, Company shall remedy such nonconformance by, at Company's option, adjustment or repair or replacement of the item and any affected part of the product(s). Purchaser shall assume all responsibility and expense for removal, reinstallation, and freight in connection with the foregoing remedies. The same obligations and conditions shall extend to replacement parts furnished by Company hereunder. Company shall have the right of disposal of parts replaced by it. Purchaser agrees to notify Company, in writing, of any apparent defects in design, material or workmanship, prior to performing any corrective action back-chargeable to the Company. Purchaser shall provide a detailed estimate for approval by the Company.

ANY SEPARATE LISTED ITEM OF THE PRODUCT(S) WHICH IS NOT MANUFACTURED BY THE COMPANY IS NOT WARRANTED BY COMPANY and shall be covered only by the express warranty, if any, of the manufacturer thereof.

THIS STATES THE PURCHASER'S EXCLUSIVE REMEDY AGAINST THE COMPANY AND ITS SUPPLIERS RELATING TO THE PRODUCT(S), WHETHER IN CONTRACT OR IN TORT OR UNDER ANY OTHER LEGAL THEORY, AND WHETHER ARISING OUT OF WARRANTIES, REPRESENTATIONS, INSTRUCTIONS, INSTALLATIONS OR DEFECTS FROM ANY CAUSE.

Company and its suppliers shall have no obligation as to any products which has been improperly stored or handled, or which has not been operated or maintained according to instructions in Company or supplier furnished manuals.



Goulds Pumps and the ITT Engineered Blocks Symbol are registered trademarks and tradenames of ITT Corporation.

SPECIFICATIONS ARE SUBJECT TO CHANGE WITHOUT NOTICE.

IM158 Revision Number 2 May, 2009

Copyright (c) 2009 ITT Corporation

Engineered for life