



# ITT

## HYDROVAR

### Pump Control

### Quick Start Guide



**Startup of a Hydrovar drive or Packaged Hydrovar Pump/Drive. Consult IM223 for recommended system design, including pump, valves, transducer, and diaphragm tank. For additional applications, consult IM223.**

Must be installed by qualified personnel.

1. Align drive on 3 Ph/TEFC motor and attach to motor using 4 clamps and screws provided. Remove cover.
2. Verify power is off before connecting to drive. Attach power wires to pump mounted fused disconnect (if packaged product) or from wall mounted fused disconnect or breaker box. Use fast acting Class T fuses. Route wires through cable gland, conduit plate – large opening –and through cable gland nut.

3. Attach Power wires to drive: Attach ground wire to ground screw. If 1 Ph, attach L and N to appropriately labeled terminals. If 3 Ph, attach wires to appropriate L1, L2, L3 terminals. See IOM for terminal locations.

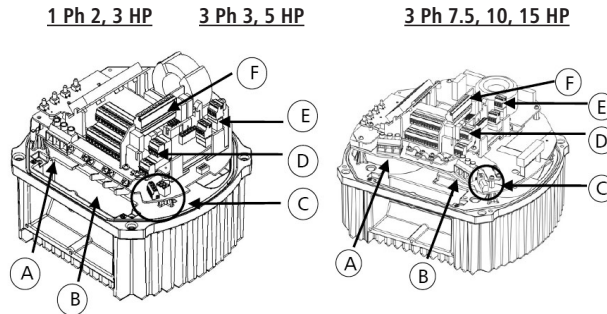

- |   |                       |   |
|---|-----------------------|---|
| (A) Power supply  | (B) Motor connections | (C) <u>Terminal block:</u><br>- START/STOP<br>- SOLORUN<br>- RS-485 Interface |
| (D) <u>RS-485 Interface</u><br>- User interface<br>- Internal interface | (E) Status-Relays     | (F) Optional Relay Card   |

4. Drive connection to motor: Route wires through cable gland and other large conduit opening as above. Connect wires to appropriate terminals. Use crimp-on spades for sizes 2, 3, 5 HP. Terminate wires at terminals U, V, W for sizes 7.5 HP and up.

**\*\*\* Route the following low voltage wires through small conduit glands and openings as needed. \*\*\***

5. Attach transducer wires to terminals X3: 1-3; Shield, White, Brown respectively.
6. Attach thermal overload switch to motor body at conduit box screw, and terminate at the 2 terminals labeled X1 PTC. If not using Thermal overload switch, place jumper between PTC terminals.
7. Provide Emergency stop switch, or jumper between terminals X3: 7, 8.
8. Provide additional on/off switch or jumper between terminals X3: 11, 12
9. If using multiple communicating drives, attach RS485 wires to terminals X4: 4-6, (-, +, Shield respectively) on Master drives; X2: 1-3 on Basic

drives. Daisy chain communication wires starting at Master drive to all additional drives.

10. Verify all connections are secure with no stray wires. Attach ground wire from drive to cover and replace cover. Note: Be sure cover sits securely on drive without pinching any wires. Securely **HAND TIGHTEN** cover screws. Cover must be firmly attached for buttons to function properly.
11. Connect power. The display should look as follows:

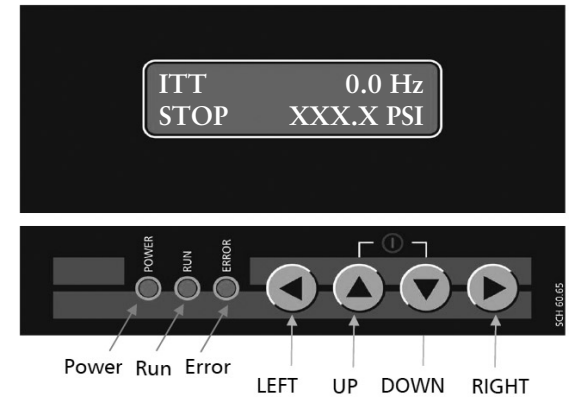

12. See attached flowchart for available programming options to change.
13. Push Right arrow to next screen to change Setpoint. Use Up/Down arrows to change setpoint, (Required value).
14. Push left arrow once to get back to main screen. Push left arrow again to get to Main menu. Use Down arrow to scroll through menu options. To change any parameter other than set point, you must first enter a password. From main menu, scroll down to Group 60, and push right arrow once to parameter 61. Enter password using up arrow key, (password = 66).
15. For multipump programming, change the highlighted parameters in the flowchart. Change: Parameter 105 to "Cascade Serial"; set the pump address to 1, 2, etc in parameter 106.
16. From main screen, press up arrow to start drive. Check rotation on pump. Switch 2 of 3 line wires from the drive at motor if reverse rotation.

